

---

aspect 

Harbour  
Specification  
Sheet.

---

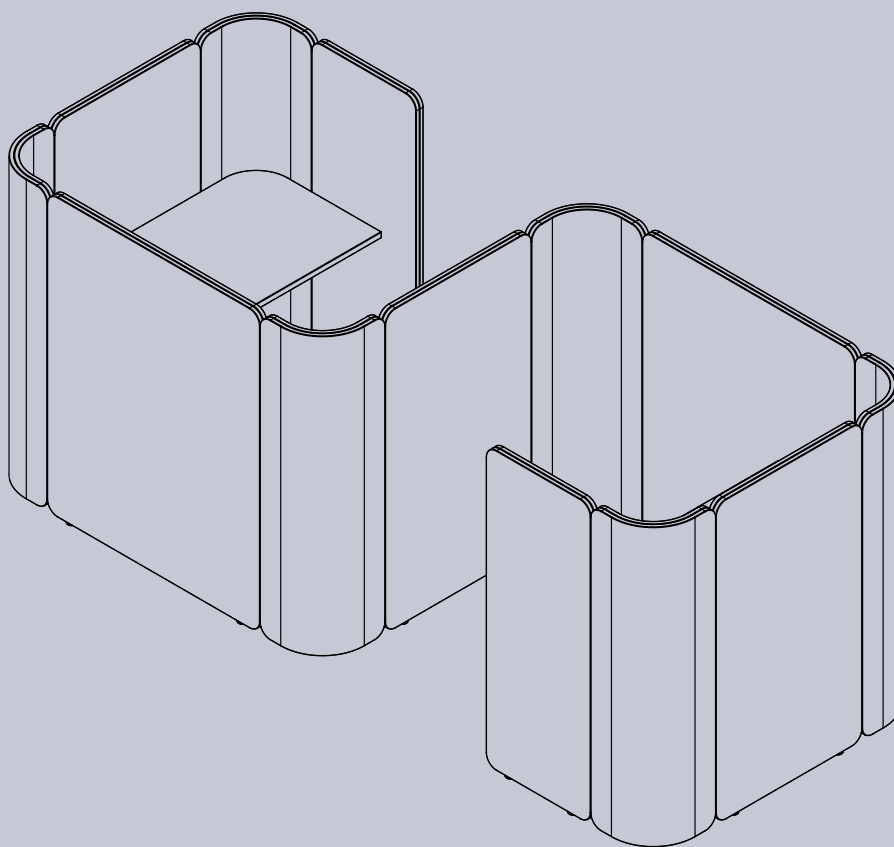



Harbour pods are private areas for busy focus periods at the office.

Harbour is a fully modular system which provides a flexible solution for open office zones and can be easily reconfigured into multiple scenarios.

Harbour pods are available as single workspaces or as multiple units. This is possible with a variety of configurations; back-to-back, angled adjacently or side by side.

Harbour can be erected, plugged in and relocated, without the need for complex or lengthy installation.

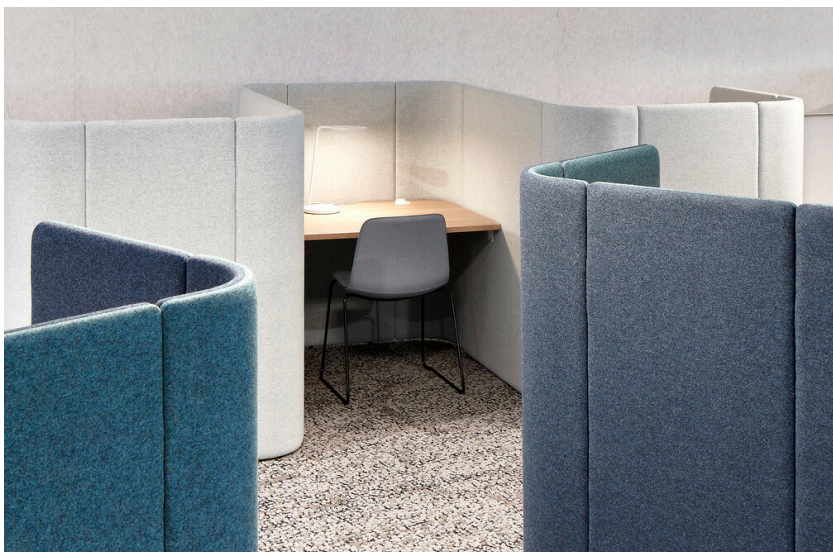

Harbour incorporates soft wiring reticulated within the panelling and can be used for phone booths.

Accessories including shelves, table lamps and coat hooks are available as extras to increase the Harbour pod functionality.



# Aspect Design.



**As furniture designers, our user-centric approach places people at the heart of every decision we make.**

Applying 40+ years' of experience and craftsmanship, we create furniture to inspire and support people in their work every day. Manufacturing locally, and with full in-house design capability, we collaborate with interior designers, architects and clients to tailor-make environments.

We're here to support you in creating workplaces that encourage productivity, creativity and collaboration. High-performing spaces where high-performing people are empowered to do their best work.

---

# Product specifications.

---

An Aspect product. Designed by Aspect.  
Made in New Zealand.

---

**Materials** Fabric shell with Laminate table top

**Suite variations** Semi private single  
Semi private back-to-back  
Open single  
Open back-to-back  
Open triple wave  
Cubby  
2-Person meeting booth

**Warranty** 10-Year warranty for normal commercial use

**Certifications**



Cert. TM  
Furniture, Fittings  
and Flooring  
Licence Number  
3210076

**Lead time** 6 - 8 Weeks

# Product specifications.

Harbour semi private single.

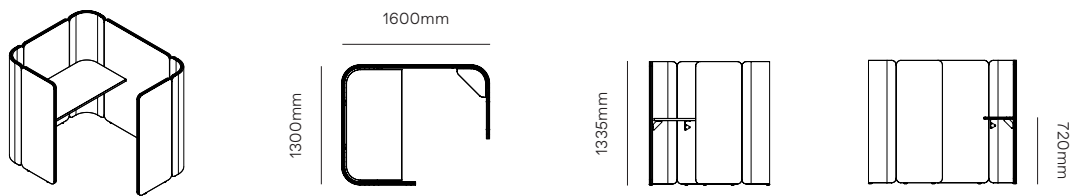

Harbour semi private back-to-back.

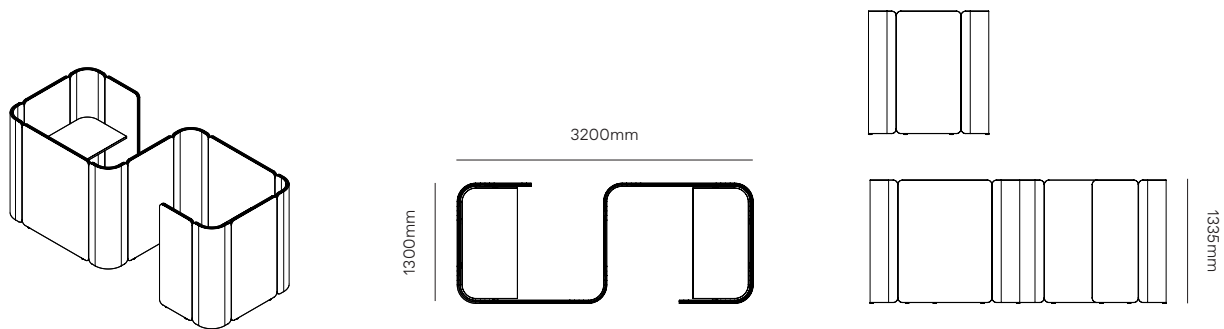

Harbour semi private singles.

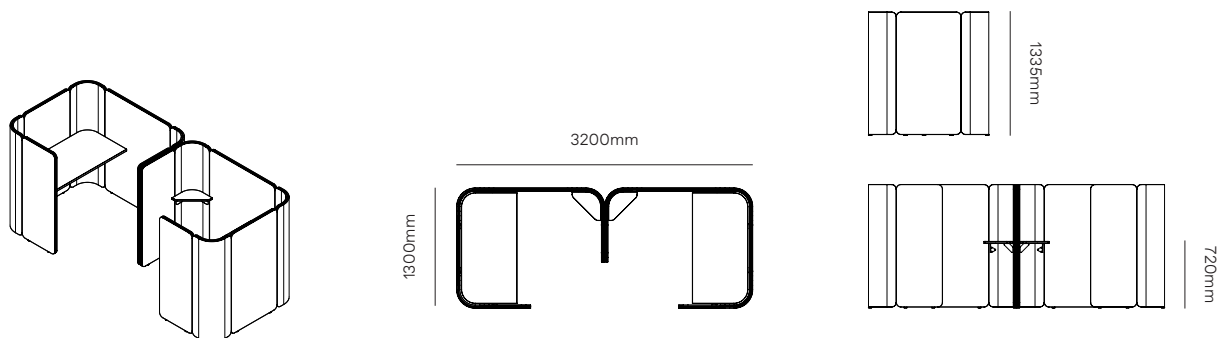

# Product specifications.

## Harbour open single.

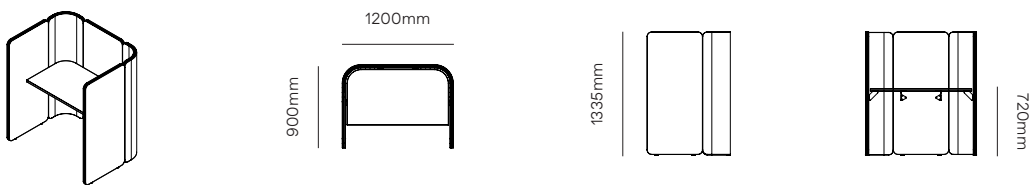

## Harbour open back-to-back.

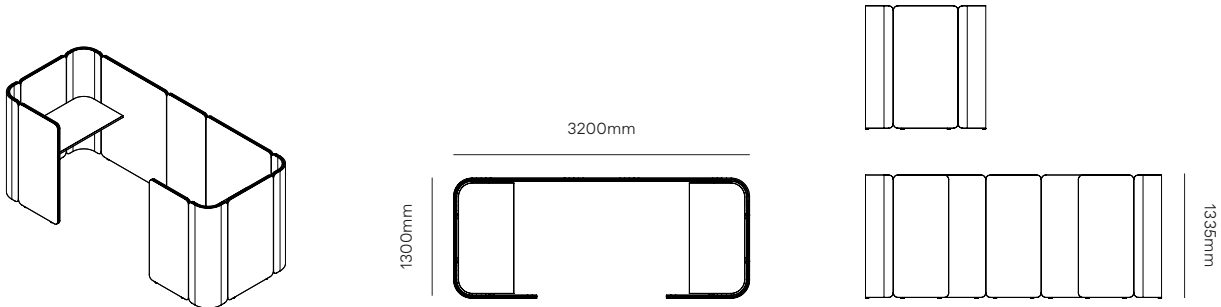

## Harbour open triple wave.

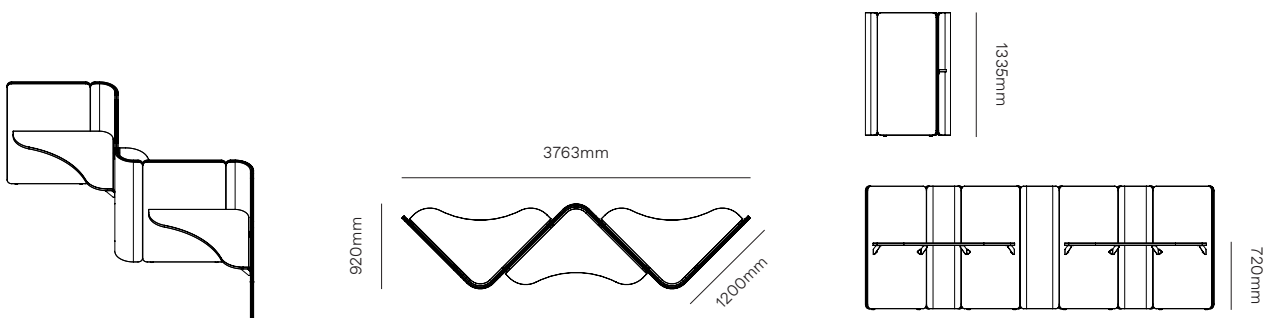

# Product specifications.

## Harbour cubby.



## Harbour 2-person meeting booth.

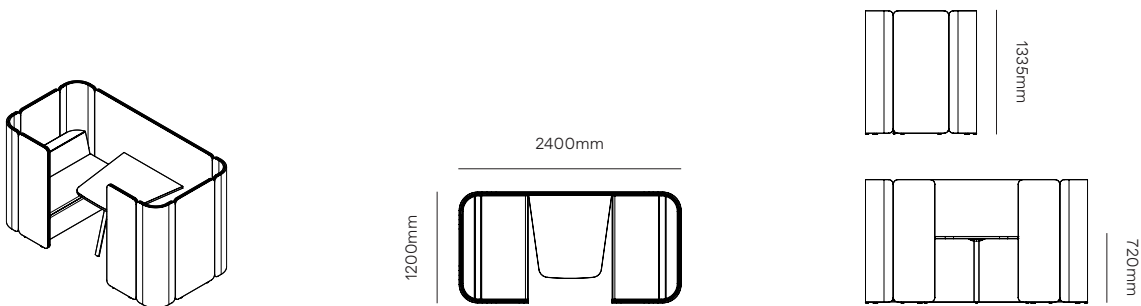



# Product specifications.

## Laminate table top finishes.



Snowdrift



Warm White

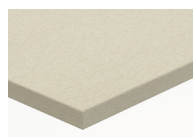

Rock Salt



Hamptons Elm



Refined Oak



Affinity Maple



Rural Oak



Raw Birch Ply

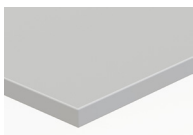

Seal Grey

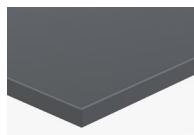

Storm



Blackened Legno

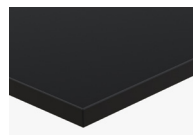

Black

## Shell upholstery.

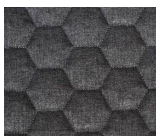

Quilt Tension



Quilt Perpetual

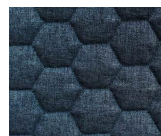

Quilt Speed

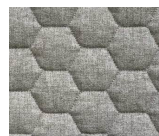

Quilt Dash



Tension



Perpetual



Speed



Dash



Impact



Enchanted

\*Custom fabric selections available



We are creative problem solvers that champion original thinking. We love sharing ideas, taking something and making it better together.

Please get in touch with us, we'd love to discuss your project.

**New Zealand**  
0800 323 220  
[info@aspectfurniture.com](mailto:info@aspectfurniture.com)

**Australia**  
1800 696 334  
[infoau@aspectfurniture.com](mailto:infoau@aspectfurniture.com)

[aspectfurniture.com](http://aspectfurniture.com)